

- * INSTALLATION IS REQUIRED BY OTHERS.
- * ALL EDGES TO HAVE 1/4" RADIUS MIN.
- * MANUFACTURING TOLERANCE $\pm 1/4$ ".
- * PRODUCT: QR-WS3436P
- * QUANTITY: _____
- * CONCRETE COLOR: _____
- * CONCRETE TEXTURE: _____
- * SEALER: STD. GLOSS SEALER
- * STD. 2"DIA. DRAIN HOLE
- * INCLUDE INTERIOR WATER SEALANT
- * STD. COLOR & TEXTURE OPTIONS

APROX. WT. 621 LBS.
(CUSTOMER TO OFFLOAD IF OVER 8000 Lbs.)

Authorized Signature Date
By signing above or stamping this drawing "approved" or "no exception taken" authorization is given to Quick Crete to produce this drawing as shown within a 1/4" tolerance.

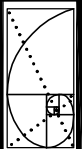
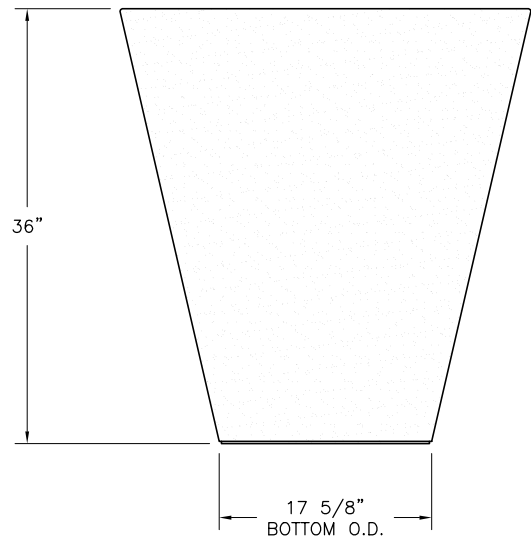
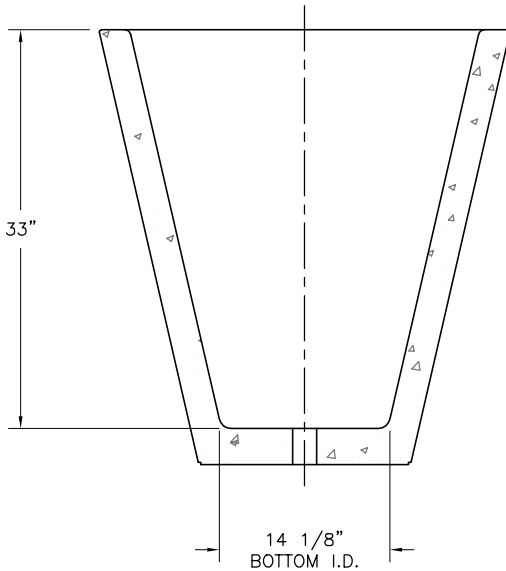
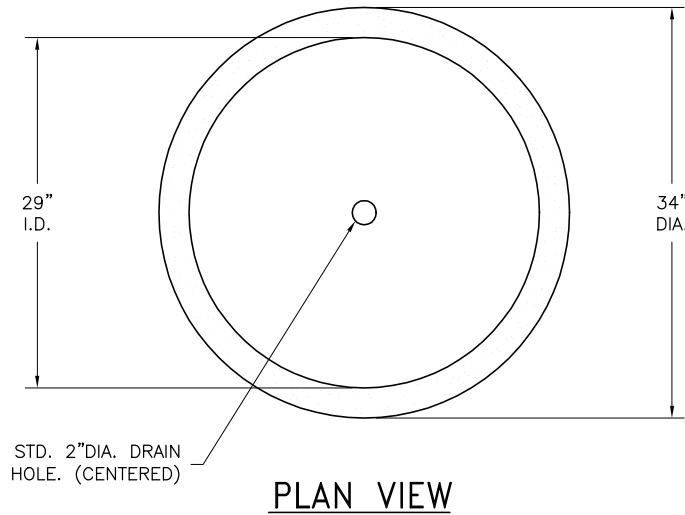

QUICK CRETE
PRODUCTS CORP.
731 PARKRIDGE AVE.
P.O. BOX 639
NORCO, CA 92860
(951) 737-6240 FAX (951) 737-7032
WWW.QUICKCRETE.COM

PLAN TYPE:	CONSTRUCTION PLAN	DATE:	10/16/08	FILE NO.:	WS3436P	SHEET	1
PRODUCT:	WILSHIRE PLANTER (QR-WS3436P)	SCALE:	3/4" = 1'	DRAWN BY:	J.A.S.	OF	1
PROJECT NAME:							