

- * INSTALLATION IS REQUIRED BY OTHERS.
- * ALL EDGES TO HAVE 1/4" RADIUS MIN.
- * MANUFACTURING TOLERANCE $\pm 1/4"$.
- * PRODUCT: QR-WS2224P
- * QUANTITY: _____
- * CONCRETE COLOR: _____
- * CONCRETE TEXTURE: _____
- * SEALER: STANDARD GLOSS SEALER
- * STD. 2"DIA. DRAIN HOLE
- * INCLUDE INTERIOR WATER SEALANT
- * STD. COLOR & TEXTURE OPTIONS

APROX. WT. 251 LBS.
 (CUSTOMER TO OFFLOAD IF OVER 8000 Lbs.)

Authorized Signature _____ Date _____
 By signing above or stamping this drawing "approved" or
 "no exception taken" authorization is given to Quick Crete
 to produce this drawing as shown within a 1/4" tolerance.

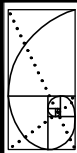
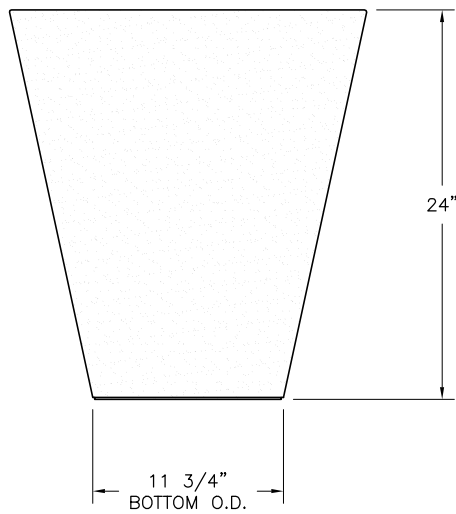
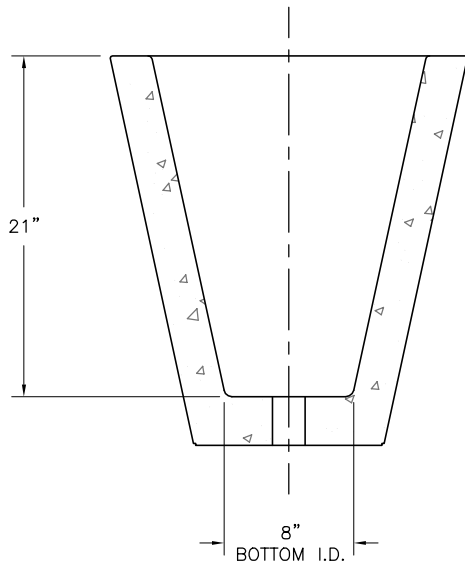
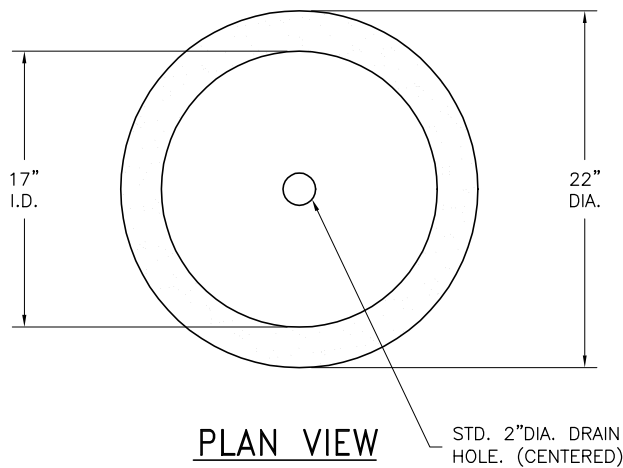

QUICK CRETE
 PRODUCTS CORP.
 731 PARKRIDGE AVE.
 P.O. Box 639
 NORCO, CA 92860
 (951) 737-6240 FAX (951) 737-7032
 WWW.QUICKCRETE.COM

PLAN TYPE:	CONSTRUCTION PLAN
PRODUCT:	WILSHIRE PLANTER (QR-WS2224P)
PROJECT NAME:	

DATE:	10/16/08
FILE NO.:	WS2224P
SCALE:	1" = 1'
DRAWN BY:	J.A.S.

SHEET	1
OF	1