

- * INSTALLATION IS REQUIRED BY OTHERS.
- * ALL EDGES TO HAVE 1/4" RADIUS MIN.
- * MANUFACTURING TOLERANCE $\pm 1/4"$.
- * PRODUCT: QR-DBR3022P
- * QUANTITY: _____
- * FINISH: SEE BELOW
- * CONCRETE TEXTURE: T1-SMOOTH
- * SEALER: MATTE
- * STD. 2"DIA. DRAIN HOLE
- * INCLUDE INTERIOR WATER SEALANT
- * LITE CRETE

APROX. WT. 165 Lbs.
 (CUSTOMER TO OFFLOAD IF OVER 8000 Lbs.)

Authorized Signature _____ Date _____
 By signing above or stamping this drawing "approved" or
 "no exception taken" authorization is given to Quick Crete
 to produce this drawing as shown within a 1/4" tolerance.

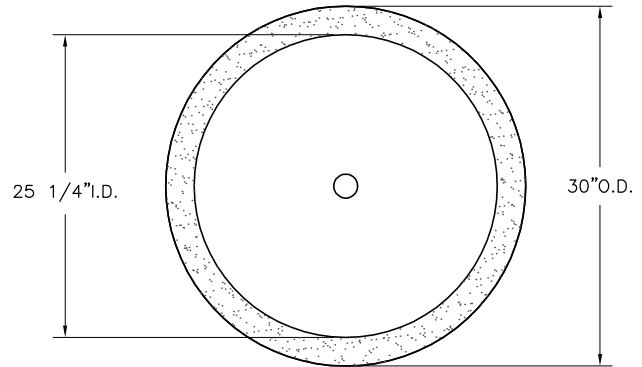

PLAN VIEW

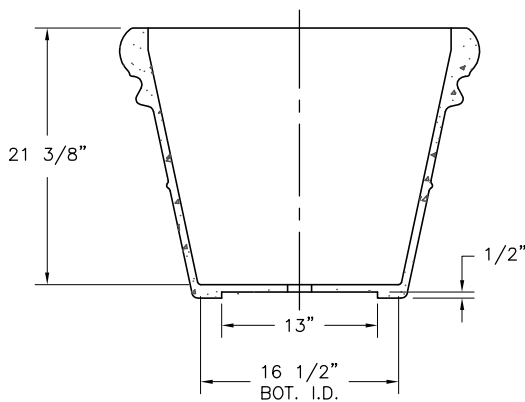

SECTION VIEW

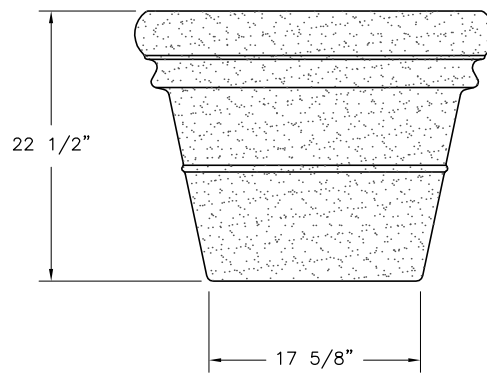

ELEVATION VIEW

K:\PLANTERS\ROUND-P\Double Rim\DBR3022P.DWG, 11/14/2005 9:05:46 AM, 1:16, MG, MG

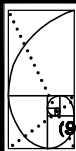

QUICK CRETE

PRODUCTS CORP.

731 PARKRIDGE AVE.

P.O. BOX 639

NORCO, CA 92860

(951) 737-6240 FAX (951) 737-7032

WWW.QUICKCRETE.COM

PLAN TYPE:	CONSTRUCTION PLAN	DATE:	11/9/99	FILE NO.	DBR3022P	SHEET	1
PRODUCT:	DOUBLE RIM PLANTER (QR-DBR3022P)	SCALE:	3/4" = 1'	DRAWN BY:	J.U.	OF	1
PROJECT NAME:							