

- * INSTALLATION IS REQUIRED BY OTHERS.
- * ALL EDGES TO HAVE 1/4" RADIUS MIN.
- * MANUFACTURING TOLERANCE $\pm 1/4"$.
- * PRODUCT: QR-CB4848P
- * QUANTITY: _____
- * CONCRETE COLOR: _____
- * CONCRETE TEXTURE: _____
- * SEALER: STANDARD GLOSS SEALER
- * 3 1/2" DIA. DRAIN HOLE
- * STD. COLOR & TEXTURE OPTIONS

* APPROX. WT. 1,130 LBS.

Authorized Signature _____ Date _____
 By signing above or stamping this drawing "approved" or
 "no exception taken" authorization is given to Quick Crete
 to produce this drawing as shown within a 1/4" tolerance.

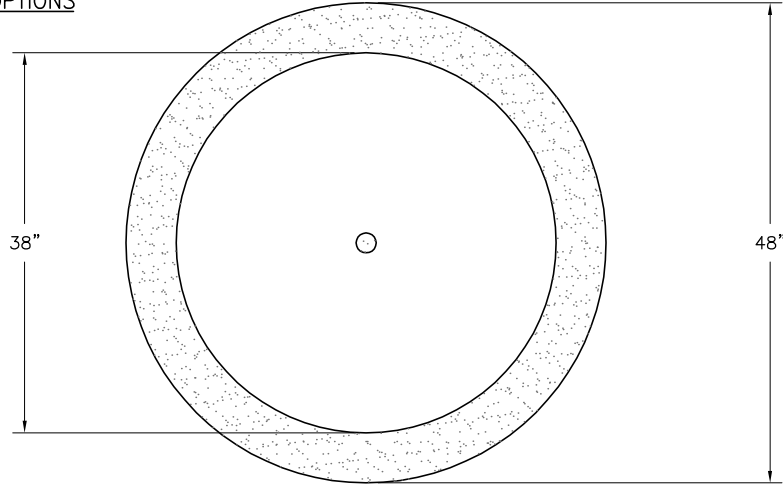

PLAN VIEW

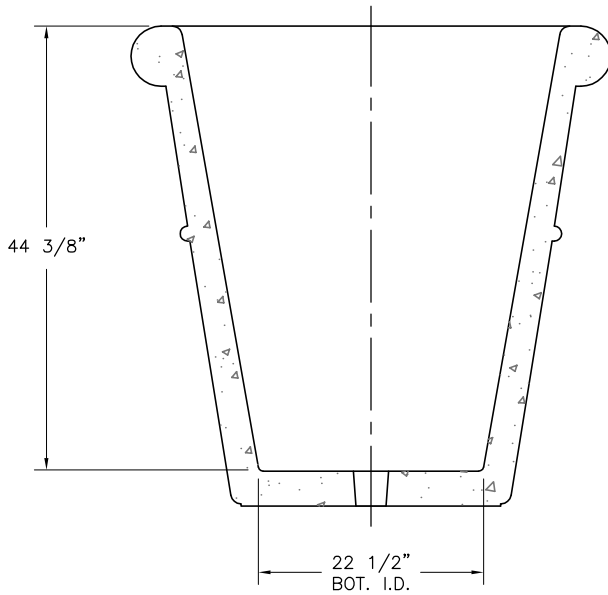

SECTION VIEW

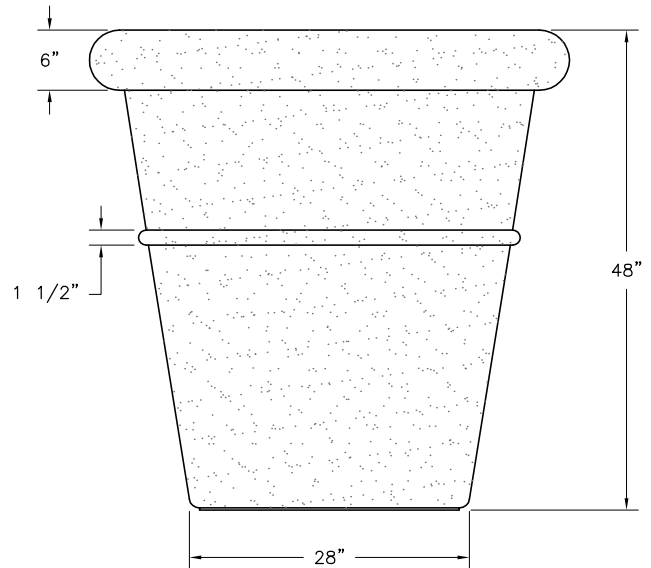

ELEVATION VIEW

K:\PLANTERS\ROUND-P\Carlsbad\CB4848.dwg, 11/11/2005 2:23:54 PM, 1:19.2, MG, MG



QUICK CRETE
 PRODUCTS CORP.
 731 PARKRIDGE AVE.
 P.O. BOX 639
 NORCO, CA 92860
 (951) 737-6240 FAX (951) 737-7032
 WWW.QUICKCRETE.COM

PLAN TYPE:	CONSTRUCTION PLAN	DATE:	8/3/00	FILE NO.	CB4848	SHEET 1 OF 1
PRODUCT:	CARLSBAD PLANTER (QR-CB4848P)	SCALE:	5/8" = 1'	DRAWN BY:	O.C.	
PROJECT NAME:						