

- * INSTALLATION IS REQUIRED BY OTHERS.
- * ALL EDGES TO HAVE 1/4" RADIUS MIN.
- * MANUFACTURING TOLERANCE $\pm 1/4"$.
- * PRODUCT: QR-CAL2422P
- * QUANTITY: _____
- * CONCRETE COLOR: _____
- * CONCRETE TEXTURE: _____
- * SEALER: STANDARD GLOSS SEALER
- * STD. 2"DIA. DRAIN HOLE
- * STD. COLOR & TEXTURE OPTIONS.

- * APPROX. WT. 400 LBS.
- * APPROX. WT. 163 LBS. (lc)

Authorized Signature _____ Date _____
 By signing above or stamping this drawing "approved" or "no exception taken" authorization is given to Quick Crete to produce this drawing as shown within a 1/4" tolerance.

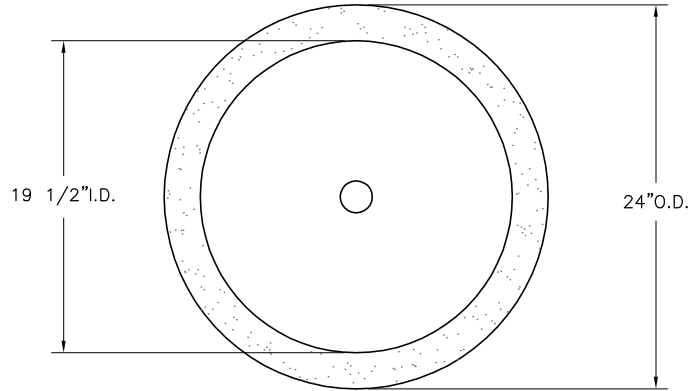

PLAN VIEW

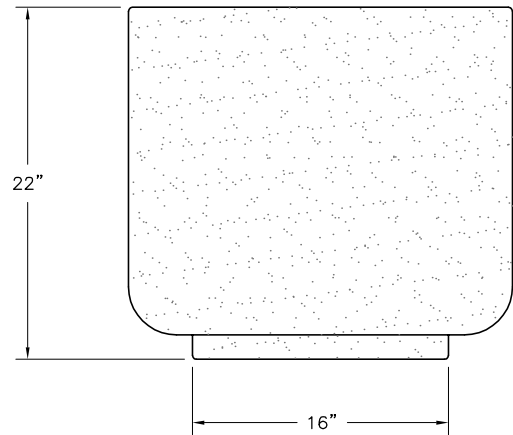
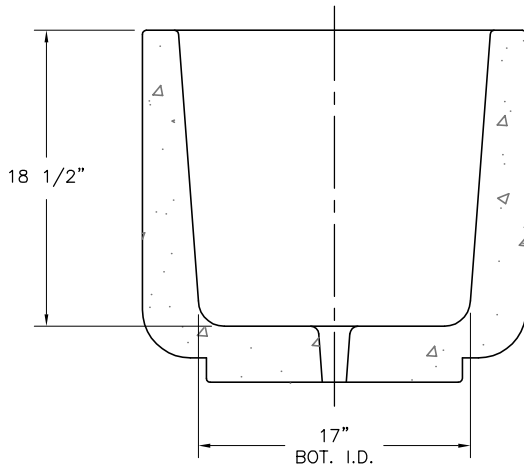

ELEVATION VIEW

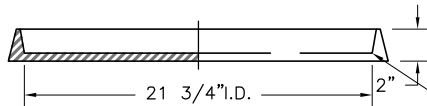

SECTION VIEW

21 3/4" I.D. STYLE "A" SAUCER
 (QR21A-S)
 QTY: _____
 COLOR: _____
 TEXTURE: _____
 SEALER: _____

K:\PLANTERS\ROUND-P\California\Cal2422.dwg, 11/11/2005 10:57:14 AM, 1:12, MG, MG

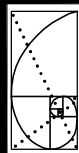

QUICK CRETE
 PRODUCTS CORP.
 731 PARKRIDGE AVE.
 P.O. BOX 639
 NORCO, CA 92860
 (951) 737-6240 FAX (951) 737-7032
 WWW.QUICKCRETE.COM

PLAN TYPE:
 PRODUCT:
 PROJECT NAME:

CONSTRUCTION PLAN
 CALIFORNIA PLANTER (QR-CAL2422P)

DATE: 1/15/99
 SCALE: 1" = 1'

FILE NO. CA2422R
 DRAWN BY: J.U./R.M.

SHEET 1 OF 1