

- \* INSTALLATION IS REQUIRED BY OTHERS.
- \* ALL EDGES TO HAVE 1/4" RADIUS MIN.
- \* MANUFACTURING TOLERANCE  $\pm 1/4"$ .
- \* PRODUCT: QR-CAL2014P
- \* QUANTITY: \_\_\_\_\_
- \* CONCRETE COLOR: \_\_\_\_\_
- \* CONCRETE TEXTURE: \_\_\_\_\_
- \* SEALER: STANDARD GLOSS SEALER
- \* STD. 2"DIA. DRAIN HOLE
- \* STD. COLOR & TEXTURE OPTIONS.

- \* APPROX. WT. 209 LBS.
- \* APPROX. WT. 82 LBS. (LC)

Authorized Signature \_\_\_\_\_ Date \_\_\_\_\_  
 By signing above or stamping this drawing "approved" or "no exception taken" authorization is given to Quick Crete to produce this drawing as shown within a 1/4" tolerance.

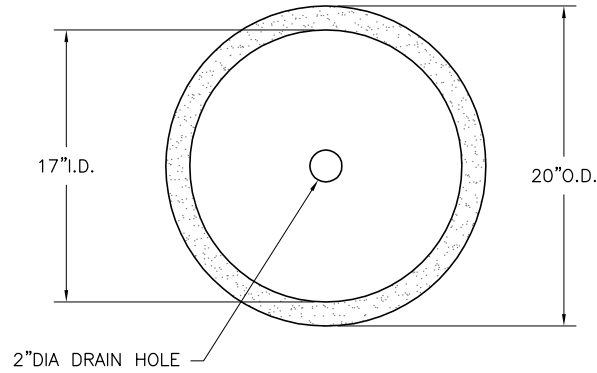

PLAN VIEW

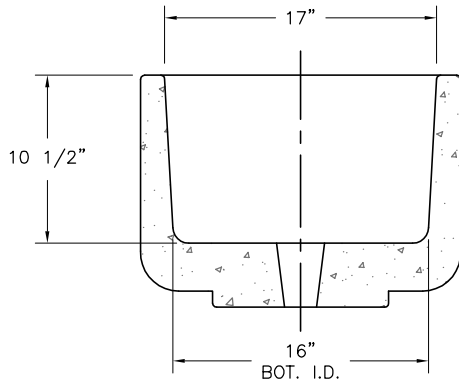

SECTION VIEW

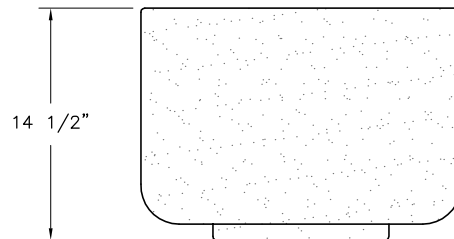

ELEVATION VIEW



**QUICK CRETE**  
 PRODUCTS CORP.  
 731 PARKRIDGE AVE.  
 P.O. BOX 639  
 NORCO, CA 92860  
 (951) 737-6240 FAX (951) 737-7032  
 WWW.QUICKCRETE.COM

PLAN TYPE:	CONSTRUCTION PLAN	DATE:	4/07/97	FILE NO.	CA2014R	SHEET	1
PRODUCT:	CALIFORNIA PLANTER (QR-CAL2014P)	SCALE:	1" = 1'	DRAWN BY:	R.M.	OF	1
PROJECT NAME:							