

- * INSTALLATION IS REQUIRED BY OTHERS.
- * ALL EDGES TO HAVE 1/4" RADIUS MIN.
- * MANUFACTURING TOLERANCE $\pm 1/4"$.
- * PRODUCT: QR-BJ4830P
- * QUANTITY:
- * CONCRETE COLOR:
- * CONCRETE TEXTURE:
- * SEALER: STANDARD GLOSS SEALER
- * STD. 2"DIA. DRAIN HOLE
- * STD. COLOR & TEXTURE OPTIONS

APROX. WT. 1,320 Lbs.
 (CUSTOMER TO OFFLOAD IF OVER 8000 Lbs.)

Authorized Signature Date
 By signing above or stamping this drawing "approved" or
 "no exception taken" authorization is given to Quick Crete
 to produce this drawing as shown within a 1/4" tolerance.

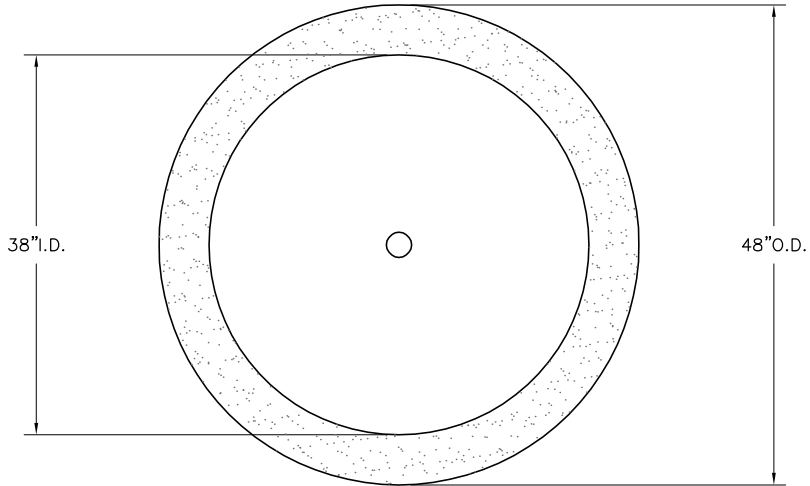

PLAN VIEW

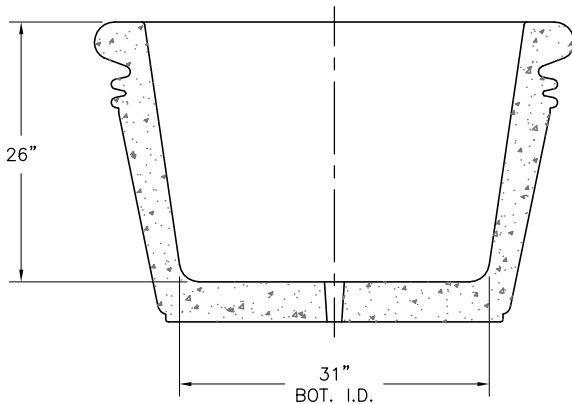

SECTION VIEW

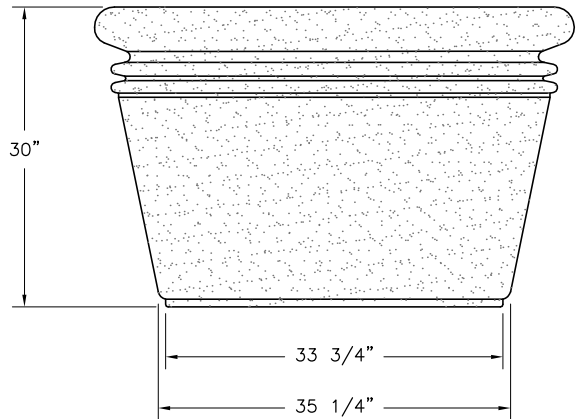

ELEVATION VIEW

K:\PLANTERS\ROUND-P\Baja\BJ4830.DWG, 11/11/2005 9:30:21 AM, 1:19Z, MG, MG

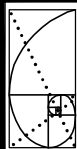

QUICK CRETE
 PRODUCTS CORP.
 731 PARKRIDGE AVE.
 P.O. BOX 639
 NORCO, CA 92860
 (951) 737-6240 FAX (951) 737-7032
 WWW.QUICKCRETE.COM

PLAN TYPE:
 PRODUCT:
 PROJECT NAME:

CONSTRUCTION PLAN
 BAJA PLANTER (QR-BJ4830-P)

DATE: 8/2/00
 SCALE: 5/8" = 1'

FILE NO. BJ4830
 DRAWN BY: J.U.

SHEET 1 OF 1