

- \* INSTALLATION IS REQUIRED BY OTHERS.
- \* ALL EDGES TO HAVE 1/4" RADIUS MIN.
- \* MANUFACTURING TOLERANCE  $\pm 1/4"$ .
- \* PRODUCT: QR-AF4225P
- \* QUANTITY: \_\_\_\_\_
- \* CONCRETE COLOR: \_\_\_\_\_
- \* CONCRETE TEXTURE: \_\_\_\_\_
- \* SEALER: STANDARD GLOSS SEALER
- \* STD. 2"DIA. DRAIN HOLE
- \* STD. COLOR & TEXTURE OPTIONS

- \* APPROX. WT. 562 LBS. (PLANTER)
- \* APPROX. WT. 132 LBS. (BASE)

Authorized Signature \_\_\_\_\_ Date \_\_\_\_\_  
 By signing above or stamping this drawing "approved" or "no exception taken" authorization is given to Quick Crete to produce this drawing as shown within a 1/4" tolerance.

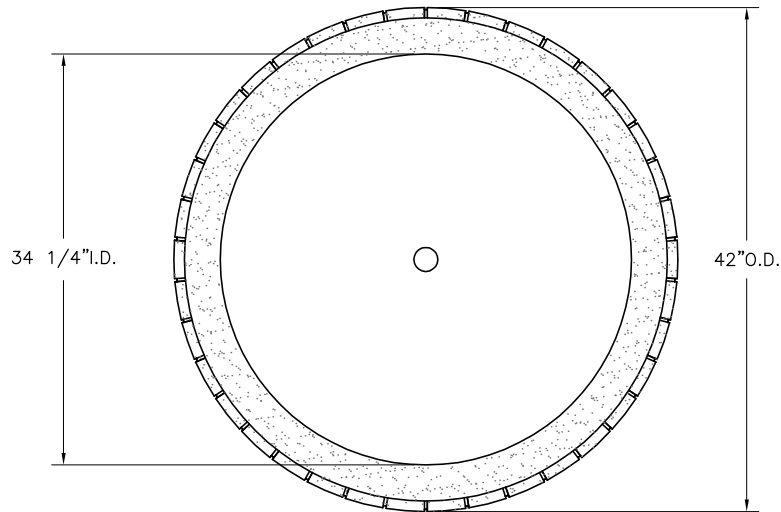

PLAN VIEW

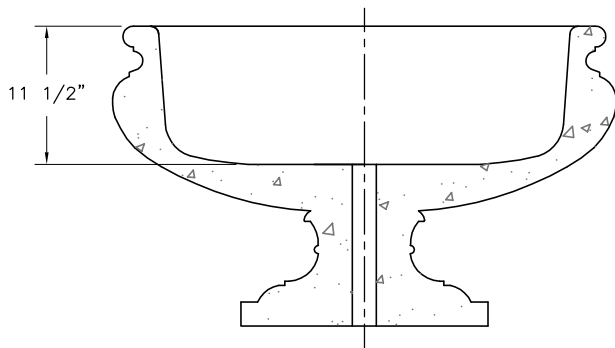

SECTION VIEW

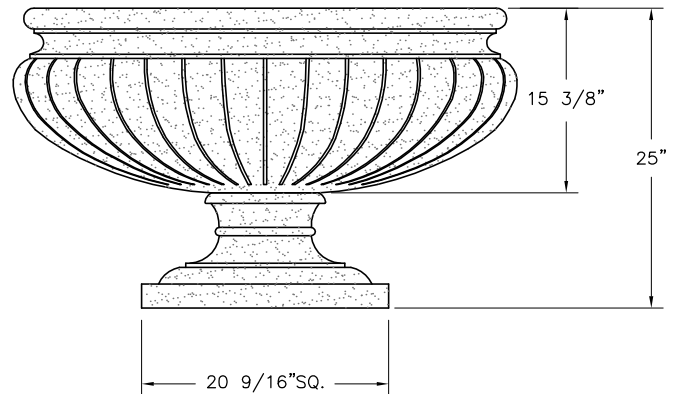

ELEVATION VIEW

K:\PLANTERS\ROUND-P\Ashford\AF4225p.dwg, 11/10/2005 3:00:02 PM, 1:16, MG, MG

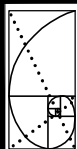

**QUICK CRETE**  
 PRODUCTS CORP.  
 731 PARKRIDGE AVE.  
 P.O. BOX 639  
 NORCO, CA 92860  
 (951) 737-6240 FAX (951) 737-7032  
 WWW.QUICKCRETE.COM

PLAN TYPE:  
 PRODUCT:  
 PROJECT NAME:

CONSTRUCTION PLAN  
 ASHFORD PLANTER (QR-AF4225P)

DATE:  
 4/27/01  
 SCALE:  
 3/4" = 1'

FILE NO.  
 AF4225P  
 DRAWN BY:  
 R.M.

SHEET  
 1  
 OF  
 1