

- \* INSTALLATION IS REQUIRED BY OTHERS.
- \* ALL EDGES TO HAVE 1/4" RADIUS MIN.
- \* MANUFACTURING TOLERANCE  $\pm 1/4"$ .
- \* PRODUCT: QR-AZ3030P
- \* QUANTITY: \_\_\_\_\_
- \* CONCRETE COLOR: \_\_\_\_\_
- \* CONCRETE TEXTURE: \_\_\_\_\_
- \* SEALER: STANDARD GLOSS SEALER
- \* STD. 2"DIA. DRAIN HOLE
- \* STD. COLOR & TEXTURE OPTIONS

- \* APPROX. WT. 913 LBS.
- \* APPROX. WT. 221 LBS. (LC)

**Authorized Signature** \_\_\_\_\_ **Date** \_\_\_\_\_  
 By signing above or stamping this drawing "approved" or  
 "no exception taken" authorization is given to Quick Crete  
 to produce this drawing as shown within a 1/4" tolerance.

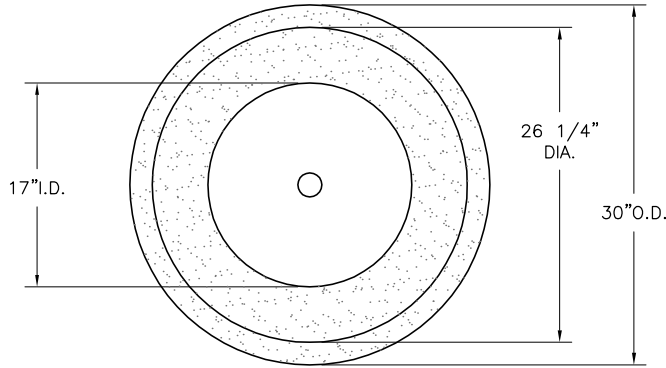

PLAN VIEW

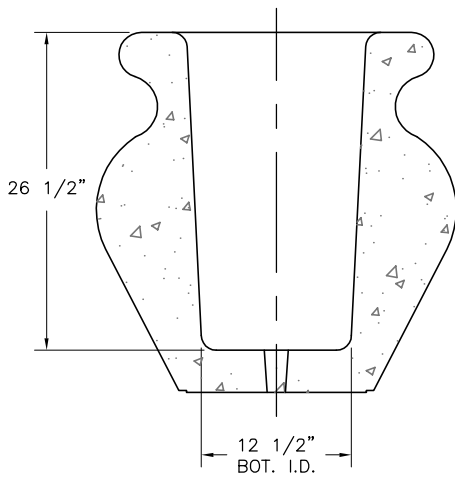

SECTION VIEW

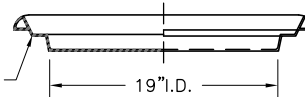
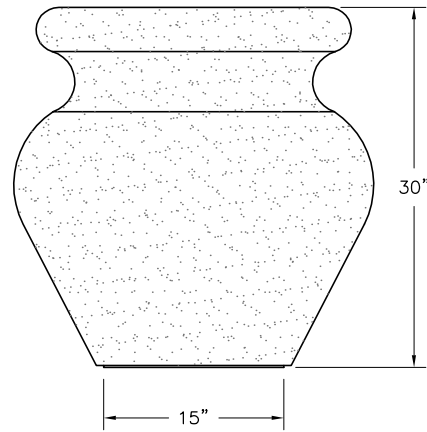

19" I.D. ROUND  
 STYLE "B" SAUCER  
 (QR-19B-S)  
 COLOR:  
 TEXTURE:  
 STD. GLOSS SEALER

ELEVATION VIEW

K:\PLANTERS\ROUND-P\Alcazar\Az3030p.dwg, 11/10/2005 2:53:31 PM, 1:16, MGS, MGS



**QUICK CRETE**  
**PRODUCTS CORP.**  
**731 PARKRIDGE AVE.**  
**P.O. BOX 639**  
**NORCO, CA 92860**  
**(951) 737-6240 FAX (951) 737-703**  
**WWW.QUICKCRETE.COM**

PLAN TYPE:  
 PRODUCT:  
 PROJECT NAME:

CONSTRUCTION PLAN  
 ALCAZAR PLANTER (QR-AZ3030P)

DATE:  
 5/25/00  
 SCALE:  
 3/4" = 1'

FILE NO.  
 AZ3030P  
 DRAWN BY:  
 J.U.

SHEET  
**1**  
 OF  
**1**