

- * INSTALLATION IS REQUIRED BY OTHERS.
- * ALL EDGES TO HAVE 1/4" RADIUS MIN.
- * MANUFACTURING TOLERANCE $\pm 1/4$ ".
- * PRODUCT: QR-AZ2424P
- * QUANTITY: _____
- * CONCRETE COLOR: _____
- * CONCRETE TEXTURE: _____
- * SEALER: STANDARD GLOSS SEALER
- * STD. 2"DIA. DRAIN HOLE
- * STD. COLOR & TEXTURE OPTIONS

- * APPROX. WT. 448 LBS.
- * APPROX. WT. 132 LBS. (LC)

Authorized Signature _____ Date _____
 By signing above or stamping this drawing "approved" or
 "no exception taken" authorization is given to Quick Crete
 to produce this drawing as shown within a 1/4" tolerance.

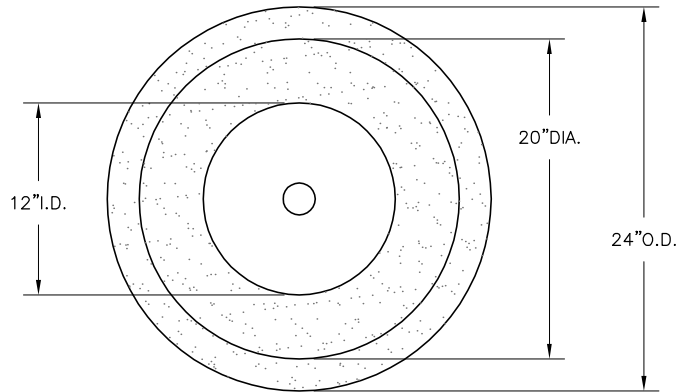

PLAN VIEW

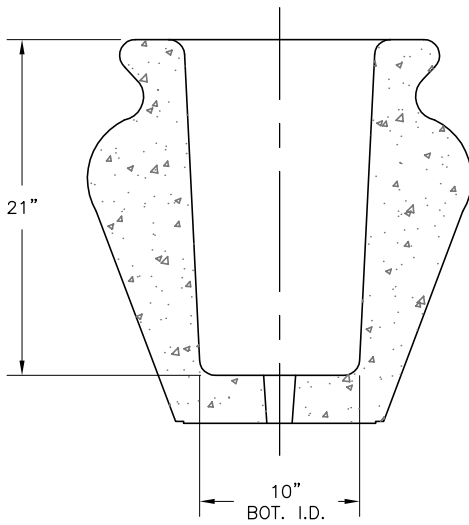

SECTION VIEW

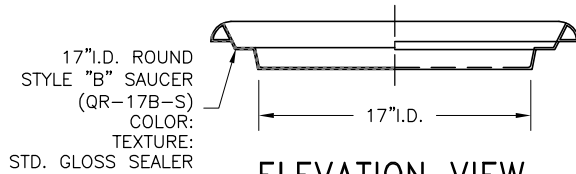
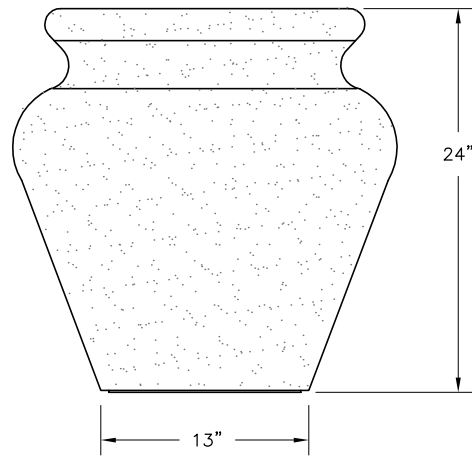

ELEVATION VIEW

K:\PLANTERS\ROUND-P\Alcazar\Az2424p.dwg, 11/10/2005 2:52:20 PM, 1:12, MGS, MGS

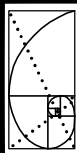

QUICK CRETE
 PRODUCTS CORP.
 731 PARKRIDGE AVE.
 P.O. BOX 639
 NORCO, CA 92860
 (951) 737-6240 FAX (951) 737-7032
 WWW.QUICKCRETE.COM

PLAN TYPE:
 PRODUCT:
 PROJECT NAME:

CONSTRUCTION PLAN
 ALCAZAR PLANTER (QR-AZ2424P)

DATE:
 11/19/01
 SCALE:
 1" = 1'

FILE NO.
 Az2424p
 DRAWN BY:
 J.U.

SHEET
 1
 OF
 1